

(See Instructions **1008-D00** for Installation, Operation and Maintenance)

Section	1008
Effective	October 2011
Replaces	June 2010

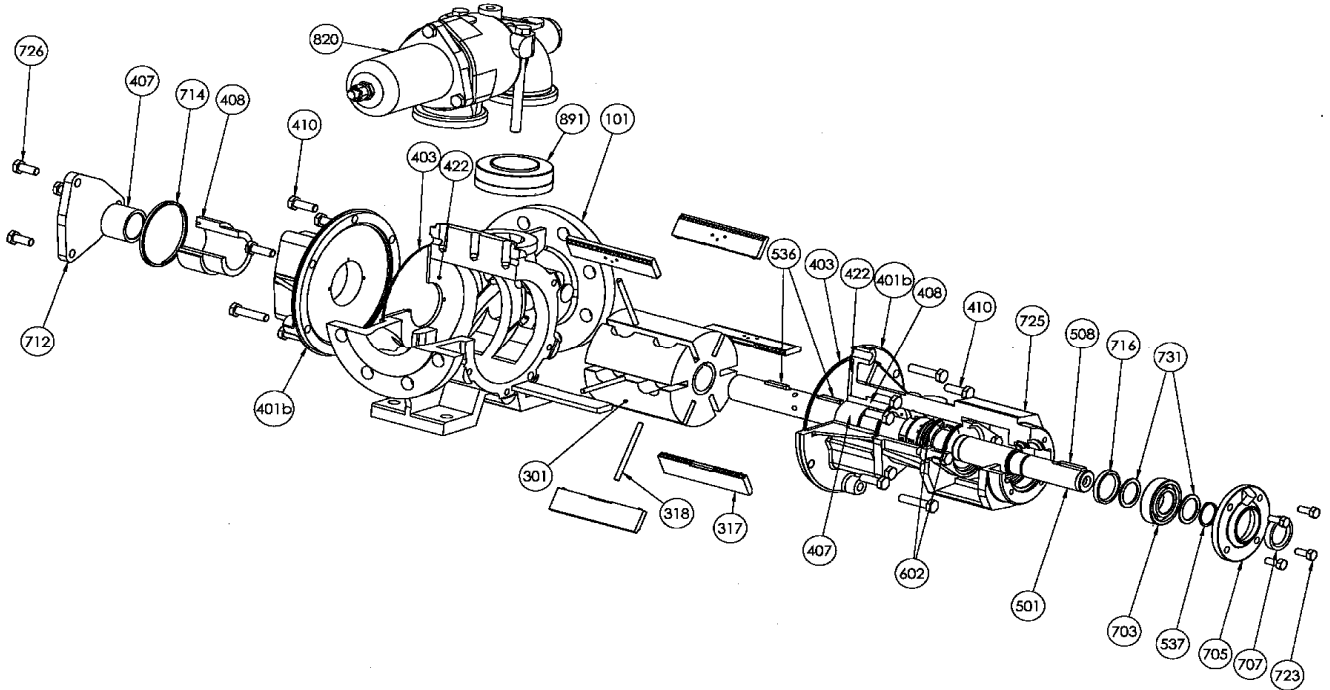

Reference			Description	Quantity		Article code		Wear parts
Ass.	Part	Available		In Pump	In comp.	P15 BI	P25 BI	
98		◆	Full set of pump screws	1		309285.00		
98		◆	Full set of jacketed pump screws	1		309286.00		
	410		Screw		(8)			
	411		Screw		(4)			
	723		Screw		(4)			
	726		Screw		(6)			
	729		Screw		(2)			
	730		Nut		(2)			
99		◆	Set of pump seals - FKM	1		307393.01		•
99		◆	Set of pump seals - CVT	1		310071.01		•
99		◆	Set of pump seals - FKM HT	1		307394.01		•
	403		Seal		(2)			
	417		Copper-plated seal		(2)			
	602		Seal		(2)			
	707		Lip seal		(1)			
	714		Cover seal		(1)			
	716		Lip seal		(1)			
	727		Outboard bearing seal		(1)			
	101	▲	Body	1		215076	214330	
	301	▲	Rotor	1		214331		
309		◆	Set of 12 vanes TVP	1		307738.00	307738.00	•
309		◆	Set of 12 vanes TVP with holes	1		309335.00	307739.00	•
	317		Vane		12			
325		◆	Set of 6 pushrods	1		308741.00	307379.00	•
	318		Pushrod		6			

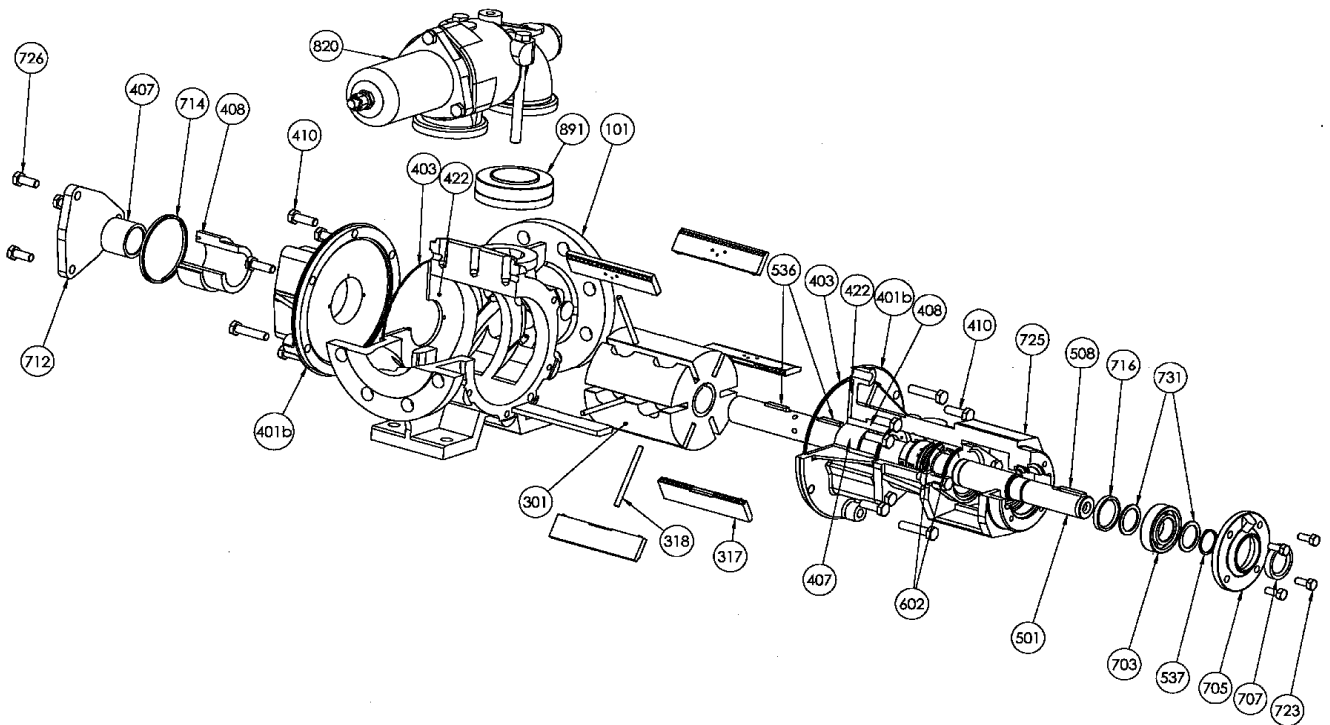

Reference			Description	Quantity		Article code		Wear parts
Ass.	Part	Available		In Pump	In comp.	P15 BI	P25 BI	
400		◆	COMPLETE FRONT COVER FOR STANDARD PUMP :					
400		◆	Standard version	2		309291.00		•
400		◆	Standard version - Enlarged clearance	2		312401.03		•
400		◆	HT version	2		314481.00		•
400		◆	HT version - Enlarged clearance	2		314482.00		•
	401		Front cover		(1)			
	410		Screw		(4)			
	411		Screw		(2)			
	419		Bushing set		(1)			
	423		Pin		(1)			
400		◆	COMPLETE FRONT COVER FOR JACKETED PUMP :					
400		◆	Standard version	2		309292.00		•
400		◆	Standard version - Enlarged clearance	2		312402.03		•
400		◆	HT version	2		314483.00		•
400		◆	HT version - Enlarged clearance	2		314484.00		•
	401		Front cover		(1)			
	410		Screw (Qty 2 for Enlarged clearance)		(4)			
	411		Screw (Qty 1 for Enlarged clearance)		(2)			
	416		Plug (Qty 2 for Enlarged clearance)		(1)			
	417		Copper-plated seal (Qty 2 for Enlarged clearance)		(1)			
	419		Bushing set		(1)			
	423		Pin		(1)			
409		◆	Set of front cover o-rings - FKM	1		307396.00		•
409		◆	Set of front cover o-rings - CVT	1		310359.00		•
409		◆	Set of front cover o-rings - FKM HT	1		307397.00		•
	403		Seal		(2)			
420		◆	Set of carbon bushings - Standard version	1		309294.00		•
420		◆	Set of carbon bushings - Standard version - Enlarged clearance	1		312400.03		•
420		◆	Set of carbon bushings - HT version	1		314557.00		•
420		◆	Set of carbon bushings - HT version - Enlarged clearance	1		314558.00		•
	407		Front cover bushing		(2)			
424		◆	Set of carbon discs - Standard version	1		309325.00		•
424		◆	Set of carbon discs - HT version	1		314541.00		•
	422		Front cover disc		(2)			
500		◆	Shaft complete for pump without pushrods	1		309295.00		
500		◆	Shaft complete for pump with pushrods	1		309296.00		
	501		Shaft		(1)			
	599		Set of keys		(1)			
599		◆	Set of keys - Pump without pushrods	1		309297.00		
599		◆	Set of keys - Pump with pushrods	1		309298.00		
	508		Key		(1)			
	536		Key (Qty : 2 for pump with pushrods)		(1)			
	537		Circlip		(1)			

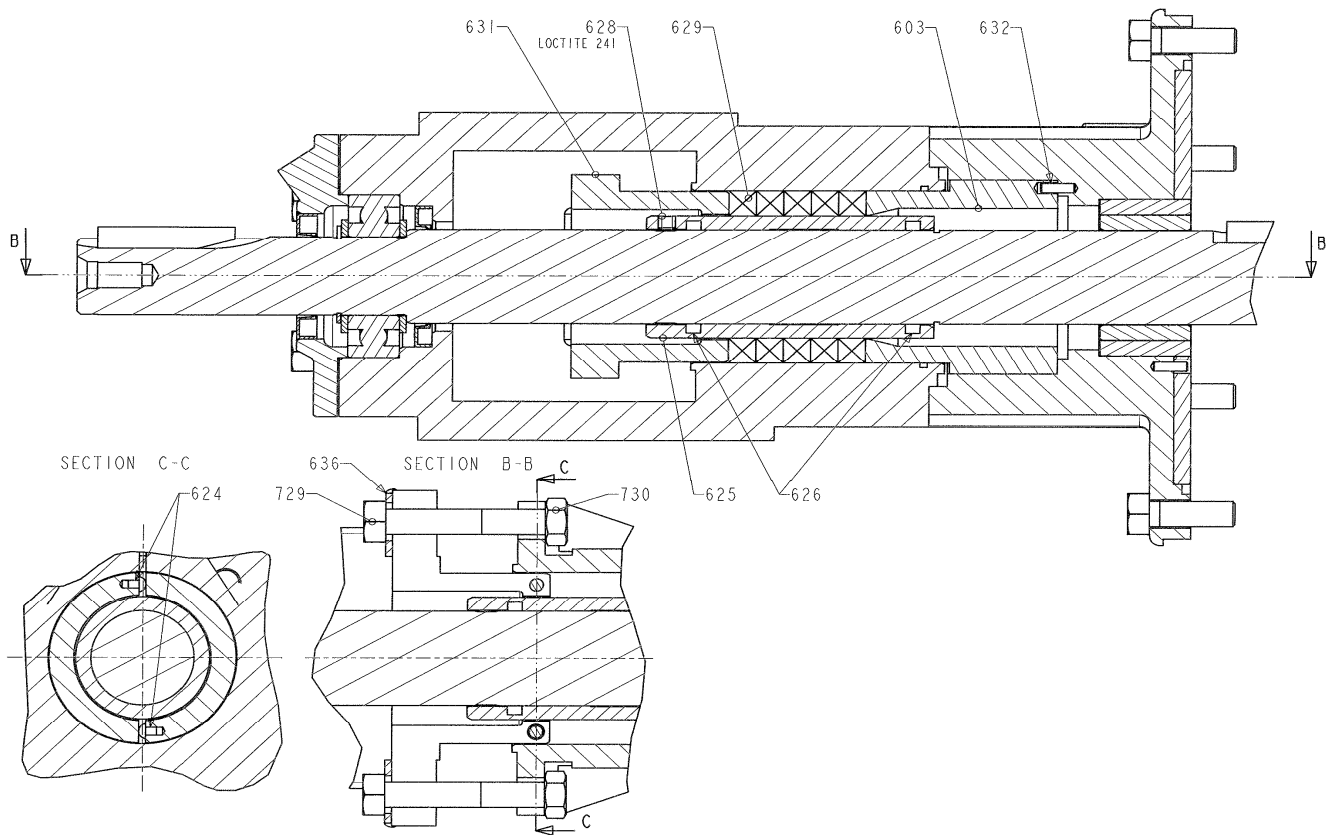

Reference			Description	Quantity		Article code		Wear parts
Ass.	Part	Available		In Pump	In comp.	P15 BI	P25 BI	
609		◆	Set Graphite gland packing - FKM	1		312433.03		
609		◆	Set Graphite gland packing - CVT	1		312435.03		
609		◆	Set Graphite gland packing - FKM HT	1		312434.03		
609		◆	Set PTFE gland packing - FKM	1		309303.00		
609		◆	Set PTFE gland packing - CVT	1		310330.00		
609		◆	Set PTFE gland packing - FKM HT	1		310329.00		
	603		Shaftseal seat		(1)			
	624		Pin (except CVT)		(2)			
	625		Jacket		(1)			
	626		Seal		(2)			
	628		Screw		(3)			
	629		Fabric		(5)			
	631		Ram		(1)			
	632		Pin		(1)			
	636		Stirrup shaftseal holder		(2)			
	729		Screw		(2)			
	730		Nut		(2)			

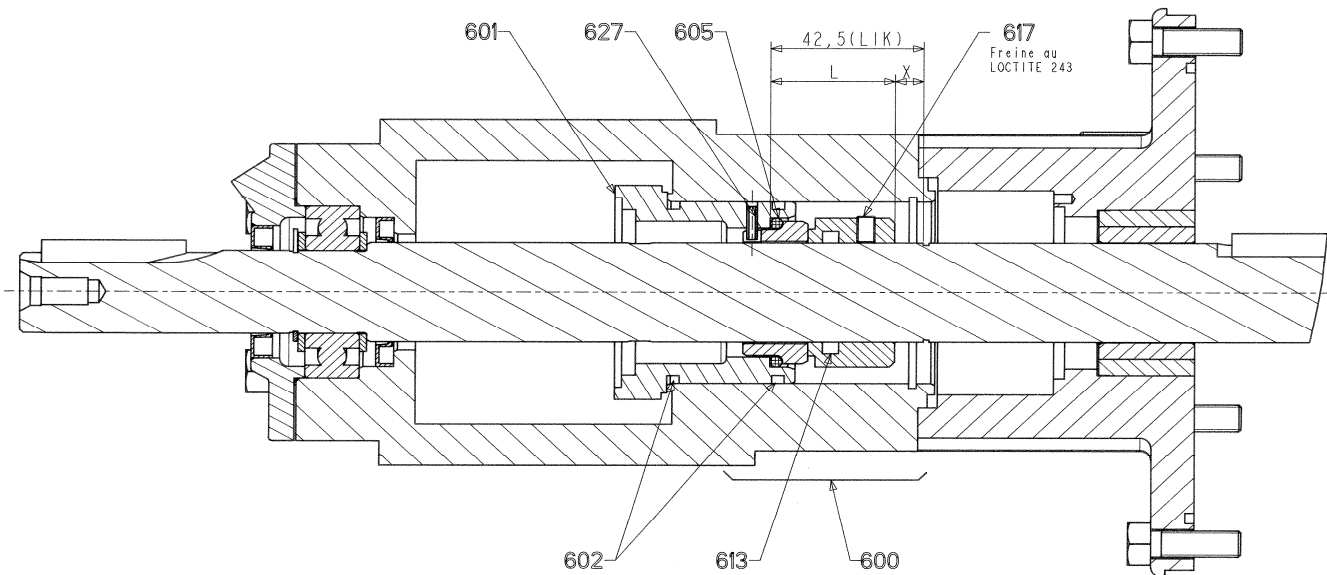

Reference			Description	Quantity		Article code		Wear parts
Ass.	Part	Available		In Pump	In comp.	P15 BI	P25 BI	
609		◆	PGSN Shaftseal holder complete - FKM	1		309299.01		
609		◆	PGSN Shaftseal holder complete - CVT	1		310325.01		
609		◆	PGSN Shaftseal holder complete - FKM HT	1		310324.01		
	511		Circlip		(1)			
	512		Spacer		(1)			
	601		Shaftseal holder		(1)			
	602		Seal		(2)			
	627		Pin		(1)			
	729		Screw		(2)			
	730		Nut		(2)			

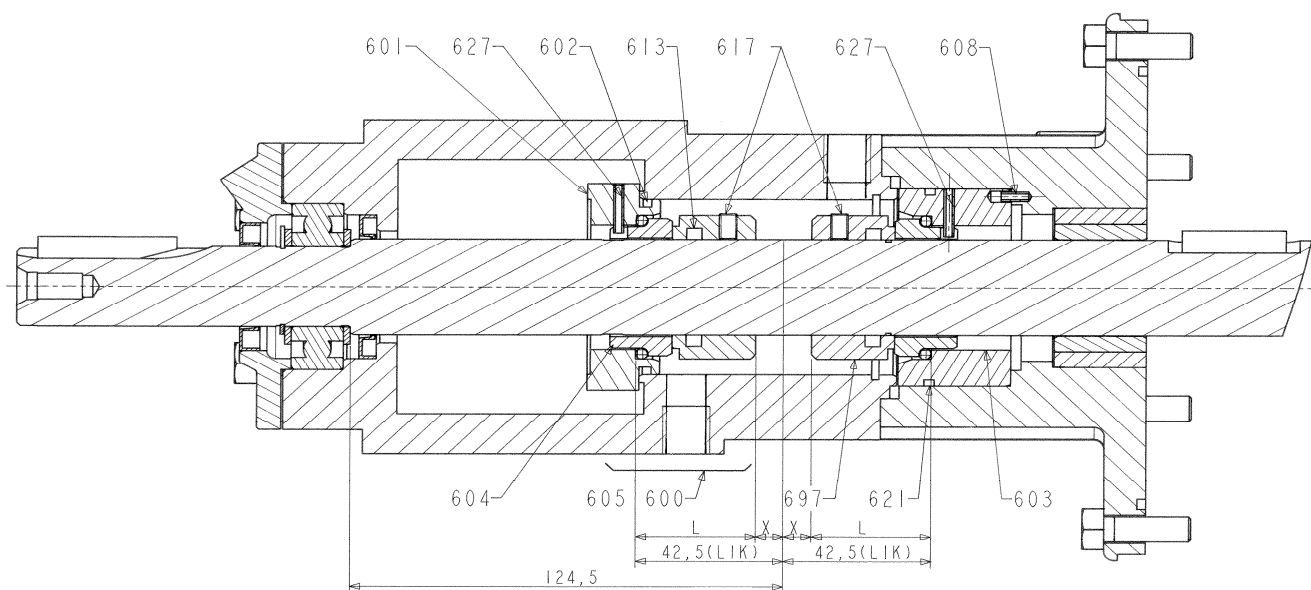

Reference			Description	Quantity		Article code		Wear parts
Ass.	Part	Available		In Pump	In comp.	P15 BI	P25 BI	
609		◆	PGDN Shaftseal holder complete - FKM	1		309301.00		
609		◆	PGDN Shaftseal holder complete - CVT	1		310327.00		
609		◆	PGDN Shaftseal holder complete - FKM HT	1		310326.00		
	601		Shaftseal holder		(1)			
	602		Seal		(1)			
	603		Shaftseal seat		(1)			
	608		Pin		(1)			
	621		Seal		(1)			
	627		Pin		(2)			
	729		Screw		(2)			
	730		Nut		(2)			

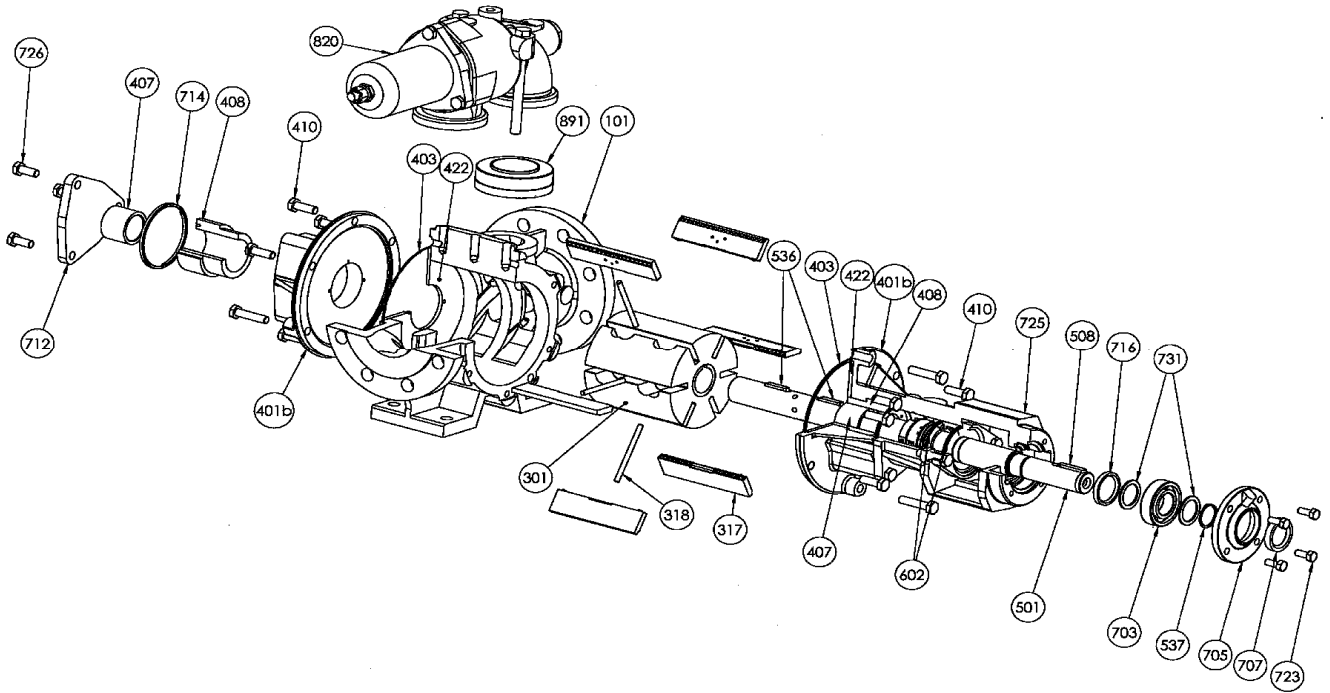

Reference			Description	Quantity		Article code		Wear parts
Ass.	Part	Available		In Pump	In comp.	P15 BI	P25 BI	
640		◆	Reservoir grease complete	1		309310.00		
	643		Snifter valve		(1)			
	644		Grease nipple		(1)			
	645		Cover		(1)			
	646		Seal		(1)			
	647		Lip seal		(1)			
699		◆	Set of gland packing seals and screws - FKM	1		309304.00		•
699		◆	Set of gland packing seals and screws - CVT	1		310333.00		•
699		◆	Set of gland packing seals and screws - FKM HT	1		310332.00		•
	626		Seal		(2)			
	628		Screw		(3)			
	632		Circlip (CVT only)		(1)			
	636		Stirrup shaftseal holder		(2)			
	729		Screw		(2)			
	730		Nut		(2)			
700		◆	Complete frond cover cover - FKM	1		309305.00		
700		◆	Complete frond cover cover - CVT	1		310336.00		
700		◆	Complete frond cover cover - FKM HT	1		310335.00		
	712		Front cover cover		(1)			
	714		Cover seal		(1)			
	726A		Screw		(3)			
704		◆	Ball bearing kit	1		309309.00		
	537		Circlip		(1)			
	703		Ball bearing		(1)			
	731		Roller bearing support washer		(2)			
715		◆	Set of seals + diverse for outboard bearing - FKM	1		309306.00		
715		◆	Set of seals + diverse for outboard bearing - CVT	1		310339.00		
715		◆	Set of seals + diverse for outboard bearing - FKM HT	1		310338.00		
	511		Circlip		(1)			
	537		Circlip		(1)			
	602		Seal		(2)			
	608		Pin		(1)			
	621		Seal		(1)			
	627		Pin		(2)			
	646		Seal		(1)			
	647		Lip seal		(1)			
	707		Lip seal		(1)			
	716		Lip seal		(1)			
	727		Outboard bearing seal		(1)			
720		◆	FOR PUMP WITH PGDN MECHANICAL SEAL :					
720		◆	Outboard bearing, complete - FKM	1		310066.00		
720		◆	Outboard bearing, complete - CVT	1		310069.00		
720		◆	Outboard bearing, complete - FKM HT	1		310068.00		
720		◆	FOR PUMP WITH OTHER MECHANICAL SEAL :					
720		◆	Outboard bearing, complete - FKM	1		309307.00		
720		◆	Outboard bearing, complete - CVT	1		310065.00		
720		◆	Outboard bearing, complete - FKM HT	1		310064.00		
	703		Ball bearing		(1)			
	716		Lip seal		(1)			
	725		Outboard bearing		(1)			
	726		Screw		(3)			
	727		Outboard bearing seal		(1)			
	731		Roller bearing support washer		(2)			

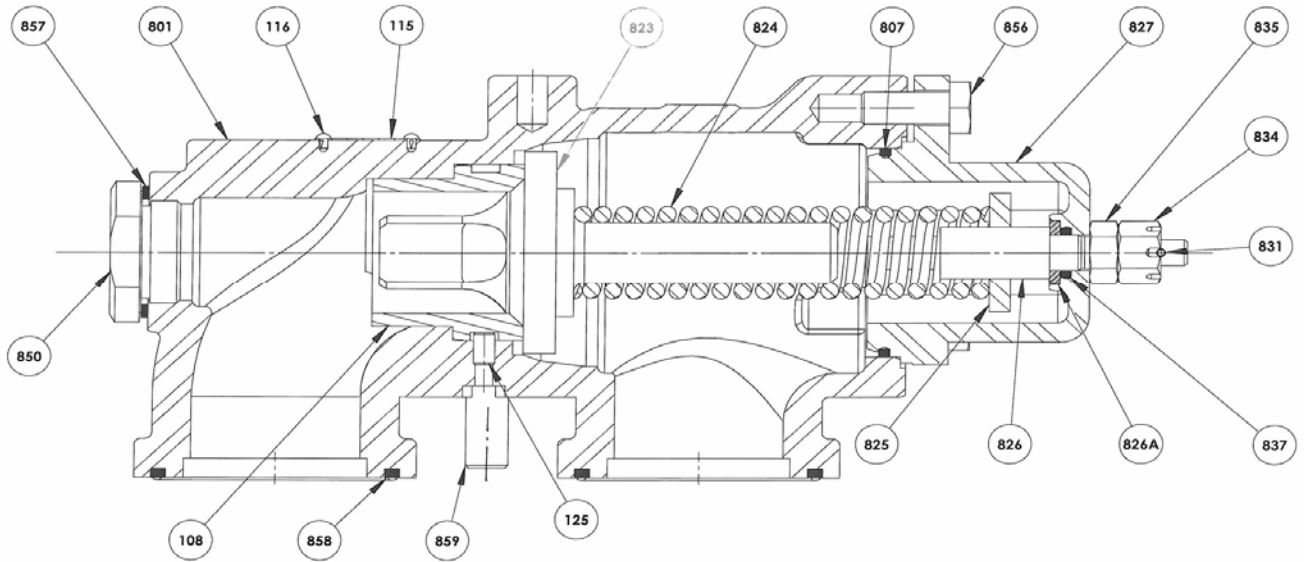

Reference			Description	Quantity		Article code		Wear parts
Ass.	Part	Available		In Pump	In comp.	P15 BI	P25 BI	
740		◆	Cover complete	1		309311.00		
	705		Bearing cover		(1)			
	707		Lip seal		(1)			
	723		Screw		(4)			
820		◆	Single bypass, complete - FKM	1		309312.02		
820		◆	Single bypass, complete - CVT	1		310342.03		
820		◆	Single bypass, complete - FKM HT	1		310341.03		
820		◆	Double bypass, complete - FKM	1		309313.03		
820		◆	Double bypass, complete - CVT	1		310345.03		
820		◆	Double bypass, complete - FKM HT	1		310344.03		
	108		Seat		(1) *			
	115		Bypass orientation plate		(1)			
	116		Plate rivet		(2)			
	125		Screw		(1) *			
	801		Bypass body		(1)			
	823	▲	Valve	1 *		219066		
	827		Cap		(1) *			
	858		Seal		(2)			
	859		Screw		(2)			
	898	◆	Pressure screw assembly - FKM	1 *		309314.00		
	898	◆	Pressure screw assembly - CVT	1 *		310348.00		
	898	◆	Pressure screw assembly - FKM HT	1 *		310347.00		
	807		Seal		(1)			
	825		Spring guide		(1)			
	826		Pressure screw		(1)			
	831		Pin		(1)			
	834		Nut		(1)			
	835		Nut		(1)			
	837		Seal		(1)			
	856		Screw		(3)			
	824	▲	2/4 bar spring	1 *		214367		
	824	▲	4/7 bar spring	1 *		215298		
	824	▲	7/12 bar spring	1 *		215299		
866		◆	Complete plug	1 *		309316.00		
	850		Seal		(1)			
	857		Plug		(1)			
868		◆	Complete stirrup - FKM	1		309315.04		
868		◆	Complete stirrup - CVT	1		310351.04		
868		◆	Complete stirrup - FKM HT	1		310350.04		
	858		Seal		(2)			
	859		Screw		(1)			
	859A		Washer		(1)			
	865		Plug		(2)			
	867		Stirrup		(1)			
	858	▲	Seal (for Stirrup) - FKM	2		200795		
	858	▲	Seal (for Stirrup) - CVT	2		215301		
	858	▲	Seal (for Stirrup) - FKM HT	2		209454		

* Quantity x 2 for double bypass

Reference			Description	Quantity		Article code		Wear parts
Ass.	Part	Available		In Pump	In comp.	P15 BI	P25 BI	
899		◆	Set of seals + diverse for bypass - FKM	1 *			309318.00	
899		◆	Set of seals + diverse for bypass - CVT	1 *			310357.00	
899		◆	Set of seals + diverse for bypass - FKM HT	1 *			310356.00	
	807		Seal		(1)			
	831		Pin		(1)			
	834		Nut		(1)			
	835		Nut		(1)			
	837		Seal		(1)			
	850		Seal		(1)			
	852		Seal		(1)			
	855		Pin		(1)			
	856		Screw		(3)			
	858		Seal		(2)			
	859		Screw		(2)			

* Quantity x 2 for double bypass

(◆) Sets of parts or (▲) parts available to order.

CVT : FEP encapsulated FKM

Keep this parts lists with Installation, Operation and Maintenance Instructions.
To order the required spare parts, indicate the appropriate CUM numbers.



Z.I. la Plaine des Isles - 2 rue des Cailottes F-89000 AUXERRE - France
Tel : +33 (0)3 86 49 86 30 • Fax : +33 (0)3 86 49 87 17
contact@mouvex.com • www.mouvex.com